

AXIAL WAREHOUSE EXHAUST FAN  
 ARRANGEMENT 4, LEVEL 1, HORIZONTAL, CEILING HUNG

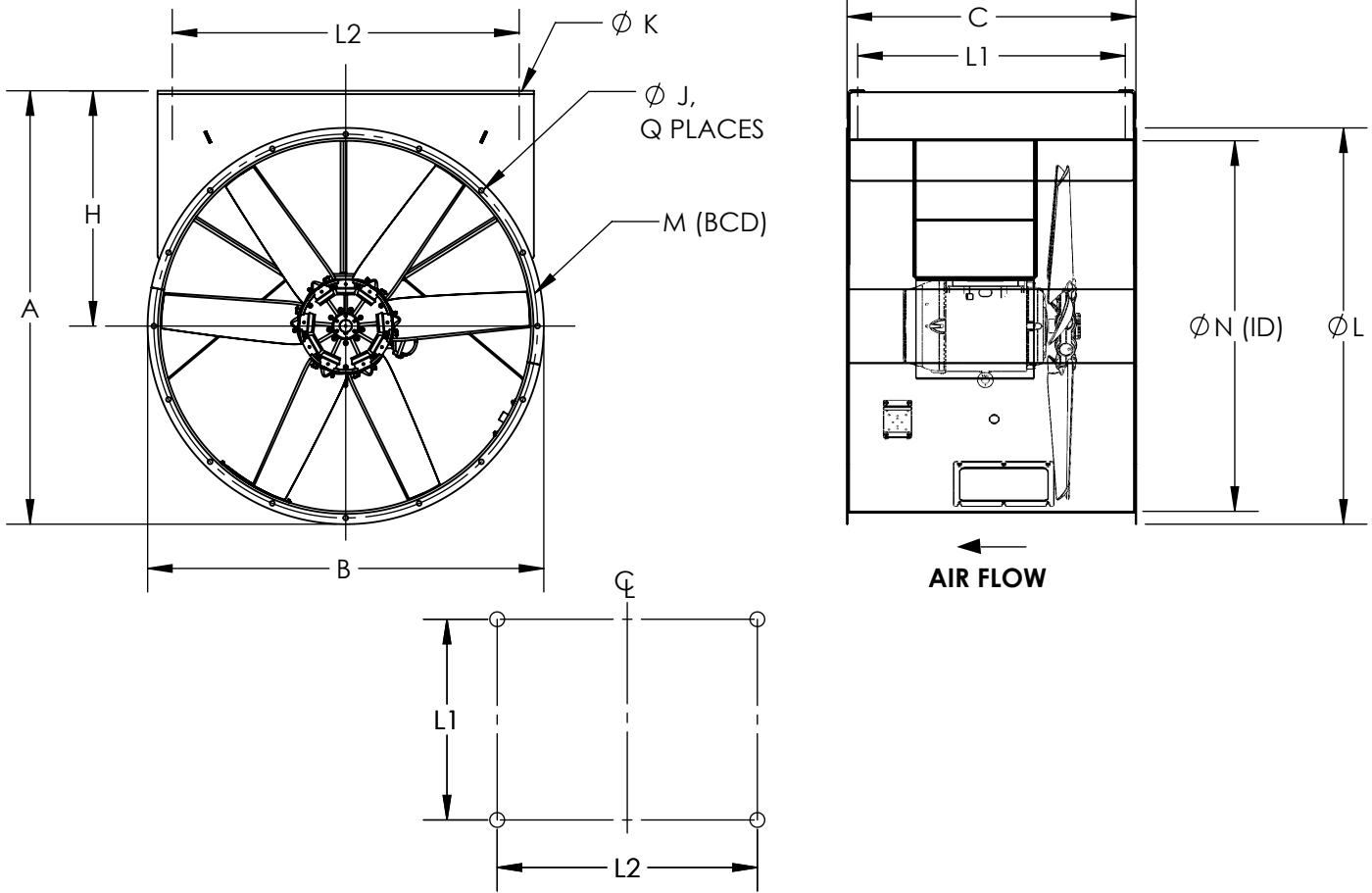

**MOUNTING HOLE PATTERN**

**STANDARD CONSTRUCTION:**

1. High efficiency adjustable pitch, cast aluminum airfoil propeller (06 or 09 blades)
2. Bolted access door
3. Bolted switch bracket
4. Air dry enamel coating

**ACCESSORIES**

1. NEMA 3R service switch
2. Mounting rails
3. Vibration isolators
4. Extended lubrication lines (PVC or copper)
5. Drain
6. Companion flange
7. Inlet bell
8. Inlet/outlet guard
9. VFD

**DIMENSIONAL DATA:**

SIZE	A	B	C	H	J	L	M	N	Q	L1	L2	MIN. MTR FRAME	MAX. MTR FRAME	UNIT WEIGHT (LESS MOTOR)
<b>AWX-1600</b>	73 3/4	67 3/8	49 1/8	40	13/16	67 3/8	65 1/4	63	16	45 1/2	59	213T	286T	1145

ALL DIMENSIONS ARE INCHES AND WEIGHTS IN LBS.

REVISION:

FORM:

REPLACES: